

<https://doi.org/10.52326/ic-ecco.2022/CE.09>



Decision Making System based on Collaborative Agents

Ana Turcan¹, ORCID: 0000-0002-9334-7606

Olesea Borozan¹, ORCID: 0000-0003-1091-5506

Victor Ababii¹, ORCID: 0000-0002-0769-8144

Viorica Sudacevschi¹, ORCID: 0000-0003-0125-3491

Silvia Munteanu¹ ORCID: 0000-0003-0749-8457

¹ Technical University of Moldova, Chişinău, bd. Ştefan cel Mare 168, ana.turcan@fcim.utm.md

Abstract— In this paper are presented the results of research done in the system projecting and research for making informed decisions based on the collaborative Agents. The mathematical model used in this research had the goal to find an optimal solution in a multi-objective space by using methods inspired by nature, especially evolutionary calculus algorithms. The calculus system's architecture consists of two sets of Agents: agents that deliver data and information, and Agents that consume it. The interconnection process between Agents is a dynamic one which evolves in time and it determines the topology of the calculus system.

Keywords— collaborative; multi-agent; decision making; nature inspired algorithms; swarm intelligence; multi-objective optimal solution search; self-reconfigurable computing architecture; ESP8266.

I. INTRODUCTION

There has been a tendency in applying the optimization algorithms inspired by nature in the last couple of years. The majority of these algorithms are metaheuristic and are based on the swarm intelligence. Swarm-intelligence-based algorithms such as cuckoo search and firefly algorithms have been found to be very efficient [1]. The analysis of different sources pictures an evolution on all major algorithms inspired by nature, like the algorithms of ants and bees, algorithms of lilacs, fireflies and flowers, genetic algorithms, differential evolution, harmonic search, swarm optimization on particles and others. Also, there is a multitude of hybrid methods, multi-objective optimization and methods to cope with constraints.

Nowadays, distributed processing of data, based on computer networks, is one of the most efficient methods of using hardware and software resources. A computer

network is a global integration of the different types of devices which allow for sharing and access from any distance: data, information, services and resources. A significant interest was developed in Grid Computing [2], which offers a detailed description of the modulus operandi and distributed processing of data based on the hierarchy with specific functions and communication protocols.

As an example of implementation of calculus models inspired by nature can be the IoT (Internet of Things) technology [3]. The IoT concept is used to define systems based on autonomous communication of a set of physical objects (sensors, devices for storing and processing data and actuators), with auto-adaptation and auto-organization capacities. The fields where IoT is applied are many, for example: smart houses and cities, industrial automation etc. IoT is based on the most innovative contributions in the projection of protocols, technologies, apps and architectures which imply intelligent things which are interconnected or they interoperate with the purpose of solving complex problems or multi-criterial optimization. An important role in the IoT technology is the fact that physical objects are virtualized which allows them to be omitted in the process of projection and development of applications.

II. COMPUTING ARCHITECTURE FOR DECISION MAKING

The decision-making calculus system based on collaborative Agents is a computing structure distributed and made out of three base components (Figure 1): set of Agents $PUBLISH Agent = \{PA_i, \forall i = \overline{1, N}\}$ which delivers data and information $TOPIC = \{topic_i, \forall i = \overline{1, N}\}$ for processing and decision-making; the set of Agents

$SUBSCRIBE Agent = \{SA_j, \forall j = \overline{1, M}\}$ which processes the data and the information $TOPICS = \{topics_j, \forall j = \overline{1, M}\}$ for generating a decision; a Server *MQTT Broker: List of TOPIC* which gathers the data and information from *PUBLISH Agent* and delivers them to *SUBSCRIBE Agent* in relation to the list of requests generated by it.

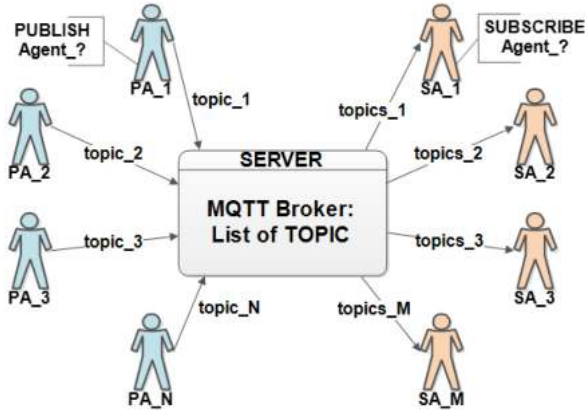

Figure 1. Computing Diagram for Decision Making.

The functionality of the decision-making system is based on the usage of the MQTT protocol [4] for the development of IoT applications. The protocol has been selected based on the analysis of the set of protocols on an application level (HTTP, MQTT, DDS, XMPP, AMQP and CoAP for IoT applications) shown in the research number [5].

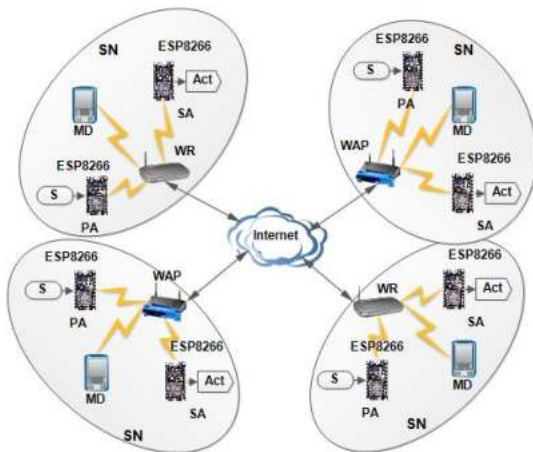

Figure 2. The Architecture of the Decision-Making System.

To implement the decision-making system based on the collaborative Agents, the devices *ESP8266* have been

selected [6, 7] which give the user the following resources: communication based on the 802.11 standard b/g/n; integrated TCP/IP protocols; RAM and Flash memory; SDIO 1.1/2.0, I2C, SPI, UART, ADC and PWM standard interfaces. All of these grant unlimited possibilities for the user in the project development process.

In Figure 2 is presented the architecture of the decision-making system based on collaborative Agents which is formed by a set of subnetworks *SN* distributed in space and connected to the global network *Internet* [8-11, 16].

Every *SN* subnetwork includes: a Wireless Router *WR* or a Wireless Access Point *WAP* which guarantee access for all devices Wi-Fi to the global network *Internet*. The set of mobile devices *MD* which will visualize data and automatically generate commands or through human operator's intervention; the set of Agents $PUBLISH Agent = \{PA_i, \forall i = \overline{1, N}\}$; and the set of Agents $SUBSCRIBE Agent = \{SA_j, \forall j = \overline{1, M}\}$.

PUBLISH Agent is an autonomous computation system and it includes: the set of sensors *S* which perceive the state of the activity or event medium; and the device *ESP8266* which performs the acquisition, processing, storing and communication algorithms in the given subnetwork.

SUBSCRIBE Agent is an autonomous computation system and it includes: the device *ESP8266* which communicates in the given subnetwork, stores and processes data, and generates decisions in accordance with the functionality algorithm; and the set of Actuators *Act* which acts on the activity medium.

III. MATHEMATICAL MODEL FOR DECISION MAKING SYSTEM

In the set $S \subset R^N$ is defined the distributed calculus process $P = \{PA, SA, X, Y, Q(X)\}$ which assures $P : S \rightarrow S$, where:

$PA = \{PA_i, \forall i = \overline{1, N}\}$ - the set of Agents which delivers data and information for the calculus process and works with other Agents;

$SA = \{SA_j, \forall j = \overline{1, M}\}$ - the set of Agents that consumes data and information to generate decisions and works with other Agents;

$PA \cap SA = \emptyset$ - the merging condition of the data and information delivering functions and their consumption for decision-making;

$X = \{x_i, \forall i = \overline{1, N}\}$ - is the state of S , which is the data and/or the information acquired from the set of sensors;

$Y = \{y_j, \forall j = \overline{1, M}\}$ - is the set of decisions to act upon the space S ;

$Q(X)$ - is the function that ensures the optimization condition of the solutions in the space S .

The functionality of the decision-making system is defined by the mathematical model (1) [10, 11]:

$$\begin{cases} Q(X) = \min_{X \in S} / \max(f_j(X^j)), \forall j = \overline{1, M^j}, \\ g_i(X) \leq 0, \forall i = \overline{1, N}, \\ h_j(X^j, y_j) = 0, \forall j = \overline{1, M}. \end{cases} \quad (1)$$

where: *min* - searching for a minimal solution of the function f in the space S ;

max - searching for a maximal solution of the function f in the space S ;

f_j - the optimization function solved by the Agent SA_j ;

X^j - the set of values of state X of the space S selected by the Agent j to solve the optimization function and to generate decisions;

M^j - the number of values of state X involved in data processing;

g_i - the system of constraints in the space S ;

h_j - the set of functions for decision-making calculus y_j based on the values of X^j .

In order to solve the quality function $Q(X)$, which is a multi-objective optimization process, the genetic algorithm with N variables is being used.

The process of solving the constraint system $g_i, \forall i = \overline{1, N}$ is uniformly distributed between the set of Agents $PA = \{PA_i, \forall i = \overline{1, N}\}$. Solving the functions f_j and $h_j, \forall j = \overline{1, M}$ is uniformly distributed between the set of Agents $SA = \{SA_j, \forall j = \overline{1, M}\}$. The calculus process is collaborative, which provides for the exchange of data between Agents at every iteration of data processing.

The decision-making calculus $y_j, \forall j = \overline{1, M}$ is a collaborative process between the set of agents SA and PA . As a result of collaboration, self-reconfigurable computing architectures are created [9, 12-15]. The

configuration of the calculus architecture is determined by the model (2):

$$H_j(Y): X \rightarrow X^j, \forall j = \overline{1, M} \quad (2)$$

where $H_j(Y)$ is the function that evaluates the influence of the status variables X on the decision y_j . Using this method, for every computation of the decision value y_j a virtual architecture for data processing is being created which ensures the achievement of the mathematical model (1).

IV. CONCLUSION

The Multi-Agent collaborative calculus is an efficient method of implementation of distributed and concurrent data processing algorithms. Furthermore, the Multi-Agent systems offer the possibility to implement calculus models inspired by nature, especially swarm intelligence.

The decision-making system based on collaborative Agents is an architecture for distributed calculus which implements a data processing model which ensures multi-objective optimal solution search. The architecture of the calculus system is auto-reconfigurable based on a model which determines the significance of the status values in the decision-making process.

In order to implement the system were selected the *ESP8266* devices which ensure the creation of Wireless networks and the implementation of the MQTT protocol for the organization of data exchange between Agents without considering their geolocation.

ACKNOWLEDGMENT

This work was supported by the project 20.80009.5007.26 „*Models, algorithms and technologies for the control, optimization and security of the Cyber-Physical systems*”.

REFERENCES

- [1] Y. Xin-She. *Nature Inspired Optimization Algorithms*, Elsevier, 2016, 258p., ISBN: 978-0-12-416743-8.
- [2] M. Hasnain, M.H. Malik, A. Raoof, S. Ullah, A.D. Javed. *Architecture for Grin Computing*, International Journal of Computer Science and Information Security, Vol. 14, No. 11, November 2016, pp. 84-90, ISSN: 1947-5500.
- [3] M.A. Sattar, M. Anwaruddin, M.A. Ali. *A review on Internet of Things – Protocols, Issues*. International Journal of Innovative Research in Electrical, Electronics, Instrumentation and Control Engineering, Vol. 5, Issue 2, February 2017, pp. 91-97, ISSN: 2321-5526, DOI: 10.17148/IJIREEICE.2017.5217.
- [4] O. Jukie, R. Filjar, I. Hedi, E. Cirikovic. *MQTT-like Network Management Architecture*. The 44th IEEE International Convention on Information, Communication and Electronic Technology, 2021, pp. 499-503.

- [5] J. Sidna, A. Baina, N. Abdallah, H. El Alami. *Analysis and evaluation of communication Protocols for IoT Applications*. SITA'20, September 23–24, 2020, Rabat, Morocco. ACM ISBN: 978-1-4503-7733-1, <https://doi.org/10.1145/3419604.3419754>.
- [6] T.G. Oh, Ch.H. Yim, G.S. Kim. *ESP8266 Wi-Fi Module for Monitoring System Application*. Global Journal of Engineering Science and Researches, 4(1), January 2017, pp. 1-6, ISSN: 2348-8034, DOI: 10.5281/zenodo.229902.
- [7] D. Vernekar. *Smart Notice Board using NodeMCU ESP8266*. International Research Journal of Engineering and Technology, Vol. 07, Issue 04, Apr. 2020, pp. 5443-5444, ISSN: 2395-0072.
- [8] Gh. Safonov, V. Ababii, V. Sudacevschi. *Analysis of distributed computing architectures for synthesis of multi-agent systems*. European Applied Sciences Journal, № 9 2016 (September), pp. 34-37, ISSN: 2195-2183.
- [9] V. Ababii, V. Sudacevschi, Gh. Safonov. *Designing a Collective Agent for synthesis of Adaptive Decision-Making Systems*. Sciences of Europe (Praha, Czech Republic), Vol 1, No 17(17), 2017, pp. 70-75, ISSN: 3162-2364.
- [10] V. Ababii, V. Sudacevschi, R. Melnic, S. Munteanu. *Multi-Agent System for Distributed Decision-Making*. National Science Journal (Ekaterinburg, Russia), Vol 2, No 45, 2019, pp. 19-23, ISSN: 2413-5291. DOI: 10.31618/nas.2413-5291.2019.2.45.
- [11] V. Sudacevschi, V. Ababii, S. Munteanu. *Distributed Decision-Making Multi-Agent System in Multi-Dimensional Environment*. ARA Journal of Sciences, 3/2020, pp. 74-80, ISSN: 0896-1018.
- [12] S. Munteanu, V. Sudacevschi, V. Ababii, R. Braniste, A. Turcan, V. Leashcenco. *Cognitive Distributed Computing System for Intelligent Agriculture*. International Journal of Progressive Sciences and Technologies. Vol. 24, No 2, January 2021, pp. 334-342. ISSN: 2509-0119.
- [13] S. Munteanu, V. Sudacevschi, V. Ababii. *Computer Systems Synthesis Inspired from Biologic Cells Structures*. Journal of Engineering Science, June, 2022, Vol. XXIX (2), pp.91-107, ISSN: 2587-3474 / E-ISSN: 2587-3482, DOI: 10.52326/jes.utm.2022.29(2).09.
- [14] S. Munteanu, V. Sudacevschi, V. Ababii, O. Borozan, C. Ababii, V. Lasco. *Multi-Agent Decision Making System based on Membrane Computing*. The 11th IEEE International Conference on Intelligent Data Acquisition and Advanced Computing Systems: Technology and Applications. 22-25 September, 2021, Cracow, Poland, Vol. 2. pp. 851-854. ISBN: 978-1-6654-4210-7.
- [15] V. Ababii, V. Sudacevschi, S. Munteanu, V. Alexei, R. Melnic, A. Turcan, V. Struna. *Cognitive Distributed Computing System Based on Temporal Logic*. Proceedings of Workshop on Intelligent Information Systems WIIS-2021, October 14-15, 2021, Chisinau, Republic of Moldova, pp. 16-25, ISBN: 978-9975-68-415-6.
- [16] V. Ababii, V. Sudacevschi, M. Osovschi, A. Turcan, A. Nistiriuc, D. Bordian, S. Munteanu. *Distributed System for Real-Time Collective Computing*. In Proceedings of the Fifth Conference of Mathematical Society of Moldova, IMCS-2019, September 28 – October 1, 2019, Chisinau, pp. 267-274. ISBN: 978-9975-68-378-4.