

<https://doi.org/10.52326/ic-ecco.2022/EL.06>



The method of measuring the parameters of nanostructured sensors

Valeri Verjbitki¹, ORCID: 0000-0002-5008-9141

Alexei Martîniuc¹, ORCID: 0000-0003-3407-3016

¹ Center for Nanotechnology and Nanosensors, Department of Microelectronics and Biomedical Engineering, Technical University of Moldova, 168 Stefan cel Mare str., MD-2004, Chisinau, Republic of Moldova, valeri.verjbitki@adm.utm.md

Abstract — In this paper, the data obtained from the research on the development of methods for measuring the parameters of nanostructured sensors, which is based on the use of 2 amplifiers and 2 analog-digital converters for measuring the voltages at the reference voltage source and the voltage drop on the additional resistor, which eliminates the shunt effect of the resistance of the structures investigated by the resistance input of the amplifier.

Keywords — nanostructured sensors, reference voltage, input impedance

I. INTRODUCTION

In recent years, the concern about environmental pollution as well as the need for industrial safety have increased and made it necessary to continuously monitor the level of air pollution. The use of vapor or gas sensors is necessary in various aspects of modern daily life. The main task of gas sensors is to quickly and stably indicate the presence of harmful or explosive gases to create a warning that could save lives and ensure safety.

With the intensive development of nanotechnologies, copper and zinc oxides have been abundantly studied due to their applications in catalysis, gas sensors, biosensors, batteries, solar energy conversion, temperature superconductors, etc. [1].

When measuring the electrical parameters of nanostructured sensors, there are limitations on the values of the currents flowing through them, the applied voltages and the dissipated power.

Instruments for measuring high resistances are applied to the measured element sufficiently but large uncontrolled voltages and powers, which can lead to a change in the parameters of nanosensors or to their failure.

Devices that measure sensor resistances by the value of the flowing current and the voltage drop across the

sensor require the use of amplifiers with sufficiently large input resistances that significantly exceed the resistances of the sensors, which, in particular, causes certain difficulties for nanostructures.

The proposed device is free from the above disadvantages.

II. EXPERIMENTAL

Development of a measurement technique, a circuit diagram and a laboratory sample of a measuring device

III. RESULTS

The device belongs to the field of measuring technology and can be used in various measuring devices where nanostructural sensors are used that change their resistance under the influence of various physical quantities such as; gas concentration, temperature, humidity.

To measure the resistance of nanostructured sensors, measuring bridges [2] are most often used, the outputs of which are connected to the inputs of measuring amplifiers.

The closest solution is a precision analog-to-digital interface for working with resistive micro and nano sensors, which contains a measuring bridge, the power diagonal leads of which are connected to a voltage source, and the measuring diagonal leads are connected to the differential inputs of instrumental amplifiers [2].

A significant disadvantage of this method of measuring resistance is that in order to measure high resistances of nano and microstructures, it is necessary to

use differential instrumental amplifiers with high input resistances.

The main problem solved by the invention is to provide the possibility of measuring high resistances of micro and nanostructures using general-purpose differential amplifiers.

The task is achieved in that to determine the resistance of nanostructured sensors, the voltage of the reference voltage source and the voltage across an additional resistor connected in series with the measured resistance are measured, and the value of the additional resistor and the input resistance of the measuring amplifier can be significantly less than the resistance of the nanostructures.

The result of the proposal is to eliminate the influence of the input impedances of instrumental amplifiers on the measurement results and replace them with general purpose amplifiers with relatively low input impedances[3].

The proposal is illustrated by the drawing in Fig. 1, which shows the structure of the measurement method.

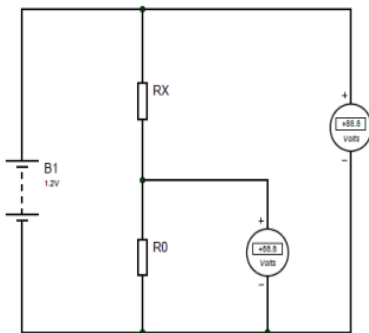

Figure 1. Two voltmeter meter

The circuit contains a reference voltage source B1. the nanostructure under study, an additional reference resistance and two voltmeters, according to the measurement results of which it is possible to calculate the resistance of the investigated nanostructure.

The basis of the proposed method for measuring the resistance of nanostructures is the rejection of the immediate the actual measurement of the voltage drop across the measured element and, as a result, the rejection of the changing amplifiers with high input impedance.

The measurement principle is explained in Fig.1. As can be seen from Fig.1. two voltages U_b and U_{r0} are measured - the source voltage and U_{r0} -voltage across the additional resistor. Voltage on the measured nanostructure:

$$U_{Rx} = U_b - U_{r0} \quad (1)$$

Current flowing through the structure:

$$I_{Rx} = U_{r0}/R_0 \quad (2)$$

Now the resistance value of the nanostructure can be calculated by the expression:

$$R_x = (U_b - U_{r0})R_0/U_{r0} \quad (3)$$

This eliminates the need to measure the voltage drop across the high-resistance resistance of the nanostructure, which, in turn, makes it possible to use to amplify the measured voltage amplifiers assembled on conventional operat

The method refers to the field of measurement technology and can be used in a variety of devices where nanosensors based on nanostructured oxides that change their resistance are used[4],[5]. The method for measuring the parameters of nanosensors and sensors based on nanostructured oxides is proposed which includes reference voltage source , operational amplifier 4, additional resistor , two voltmeters 5 and the measured nanosensor or nanostructured sensor . The resistance of the nanosensor or of the sensor based on nanostructures is determined from the value of the voltage indicated by the voltmeters.

A block diagram illustrating the proposed idea is shown in Fig.2

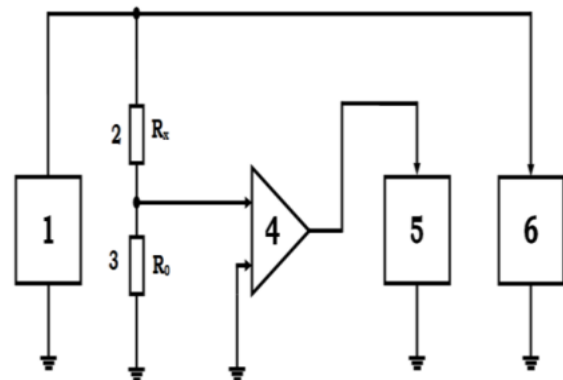

Figure 2. Principle of measurement of nanostructure parameters

It contains a series-connected reference voltage source 1, measured nanostructural sensor 2 - R_x , an additional resistor 3 to the connection point of which with a nanostructural sensor is connected to the input of amplifier 4, and its output is connected to the input of a voltmeter 5, voltmeter 6 is connected to the reference

voltage source, in addition, resistor 3, the common points of the reference voltage source 1, amplifier 4, voltmeter 5 and voltmeter 6 are connected to ground.

The process of measuring the resistance of a micro and nanostructured sensor is carried out as follows: at the first stage, the voltage across the additional resistor 3 U_{r3} is determined, which is equal to the voltage measured by the voltmeter 4 U_{v4} divided by the gain of the amplifier 4 K_{u4}

$$U_{r3} = U_{v4} / K_{u4} \quad (4)$$

at the second stage, the voltage on the nanostructured sensor is determined, which is equal to the voltage of the reference voltage source 1 measured by the voltmeter 6 U_6 minus the voltage across the additional resistor 3

$$U_{rx} = U_6 - U_{r3} \quad (5)$$

At the third stage, the current value through the nanostructured sensor is calculated

$$I_{rx} = U_{r3} / R_4 \quad (6)$$

At the fourth stage, the resistance value of the nanostructured sensor is calculated

$$R_x = U_{rx} / I_{rx} = (U_6 - U_{r3}) * R_4 / U_{r3} = (U_{v6} * K_{u4} - U_{v5}) * R_3 / U_{v5} \quad (7)$$

As an example of use in practice, you can use a practical case of implementation with the following parameters of the elements: the value of the reference voltage source $U_6 = 30V$, the resistance of the additional resistor 3 $R_3 = 1000 \text{ Ohm}$, the voltmeter reading 5 $U_5 = 20V$, the voltmeter reading 6 $U_6 = 29.98V$

$$R_x = (29.98 * 1000 - 20) * 1000 / 20 = 1498000 \text{ Ohm}$$

The block diagram of the device is shown in Fig.3.

The flowchart includes:

- reference voltage source;
 - researched nanostructured sensor R_x ;
 - additional stable resistor R_0 ;
 - DC amplifiers;
 - analog-to-digital converters;
 - microprocessor;
 - indication device - display;
 - control scheme;
 - source of power.
- the reference voltage source is designed to generate a stable thermo-independent voltage value supplied to the measuring circuit

- an additional stable resistor is used to measure the current flowing through the nano-structural sensor
- DC amplifiers lead the measured voltages to the levels necessary for normal small operation of analog-to-digital converters
- Analog to digital converters are used to convert measured voltages into digital form, which is necessary for the operation of the microprocessor (usually included in the micropro-assignor)
- the microprocessor processes the received data, calculates the resistance value of the nanostructure a four sensor and converts it into codes supplied to the indicator
- indicator (display) displays the calculated value of the resistance of the nanostructure
- the control scheme is designed to select the operating modes of the device: on / off, calibration, measurement

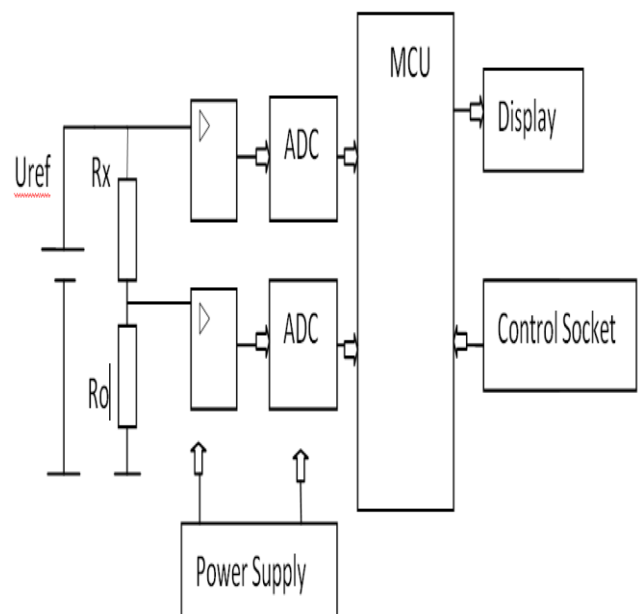

Figure 3. Device block diagram

The schematic diagram of the device is shown in Fig.4.

The investigated structure R_x together with the series calibrated resistance R_0 is under-connected to the reference voltage source B1. U_{B1} source voltage and voltage drop on a calibrated resistance U_{R0} using operational amplifiers $U_{2.A}$ and $U_{2.B}$ amplify are normalized and normalized to levels in the range (0 - 5) V, which is necessary for the operation of the analog - digital converter ADC0/ADC1 of microprocessor U_1 .

The calculated value of the nanostructure resistance is converted into control codes of four digit seven-segment LED indicator. Port C outputs (PC0 - PC7) Processors U1 determine the displayed digit, and outputs PD0 - PD3 of port D switch digits dynamic indicator.

Elements X1, C1, C2 are part of the crystal oscillator; R1b, C3 - initial reset circuit microprocessor. Control buttons 1 and 2 are used to select the operating mode of the device.

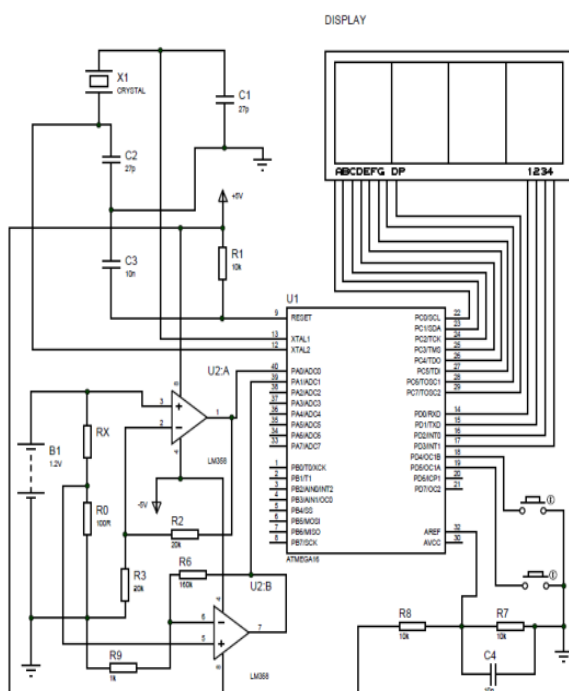

Figure 4. Electrical diagram of the device

IV. CONCLUSIONS

The method of measuring the resistance of nanosensors based on micro and nanostructured oxides,

which allow excluding the effect of the input resistances of the differential instrumentation amplifiers on the measurement results, which consists in measuring the voltage at the measured resistance in series connected of the reference voltage source and the additional resistor and calculations of these measured resistance data.

ACKNOWLEDGMENT

This paper was partially supported by the Technical University of Moldova and partially supported by the the ANCD-NARD Grant No. 20.80009.5007.09 at TUM

REFERENCES

- [1] L. Chow, O. Lupan, G. Chai, "Fabrication of ZnO nanorod-based hydrogen gas nanosensor," *United States Patent* 8263002.
- [2] Б.Н.Лозинский, И.И.Мельниченко. "Электрорадио измерения," *Энергия*, М. 1976, С 193-194
- [3] RU 2541723
- [4] O. Lupan, G. Chai, L. Chow, "Novel hydrogen gas sensor based on single ZnO nanorod," *Microelectronic Engineering*. Vol. 85, 11, 2008, p. 2220–2225.
- [5] O. Lupan, V.V. Ursaki, G. Chai, L. Chow, G.A. Emelchenko, I.M. Tiginyanu, A.N. Gruzintsev, A.N. Redkin, "Selective hydrogen gas nanosensor using individual ZnO nanowire with fast response at room temperature," *Sensors and Actuators B: Chemical*. Vol. 144, 1, 29 2010, p. 56–66.